

4 ACM

POMPE AUTOADESCANTI AD ANELLO LIQUIDO FLANGIATE
SELF-PRIMING LIQUID RING FLANGED PUMPS

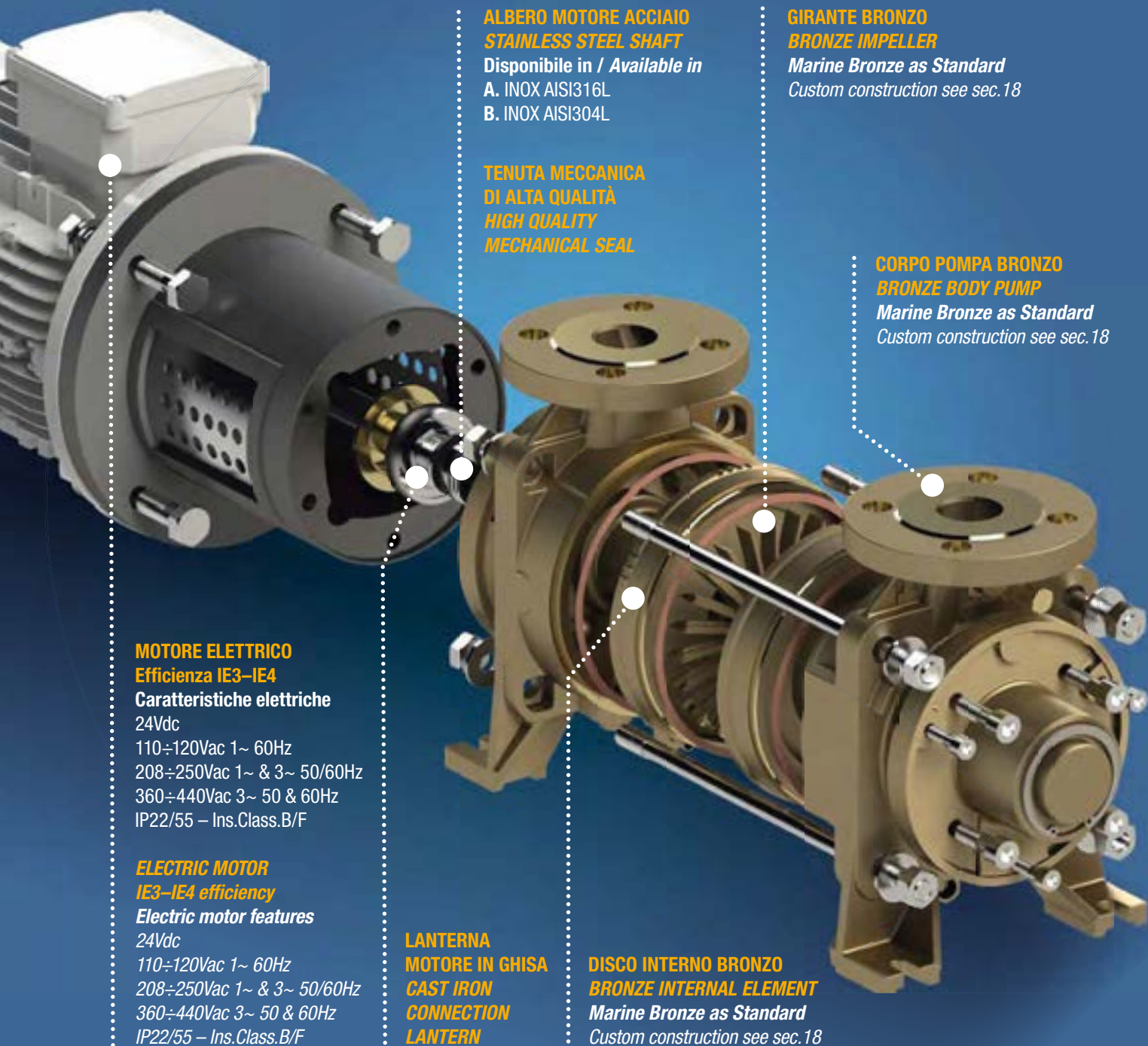

ALBERO MOTORE ACCIAIO
STAINLESS STEEL SHAFT
Disponibile in / Available in
A. INOX AISI316L
B. INOX AISI304L

GIRANTE BRONZO
BRONZE IMPELLER
Marine Bronze as Standard
Custom construction see sec.18

TENUTA MECCANICA
DI ALTA QUALITÀ
HIGH QUALITY
MECHANICAL SEAL

CORPO POMPA BRONZO
BRONZE BODY PUMP
Marine Bronze as Standard
Custom construction see sec.18

MOTORE ELETTRICO
Efficienza IE3-IE4
Caratteristiche elettriche
24Vdc
110÷120Vac 1~ 60Hz
208÷250Vac 1~ & 3~ 50/60Hz
360÷440Vac 3~ 50 & 60Hz
IP22/55 – Ins.Class.B/F

ELECTRIC MOTOR
IE3-IE4 efficiency
Electric motor features
24Vdc
110÷120Vac 1~ 60Hz
208÷250Vac 1~ & 3~ 50/60Hz
360÷440Vac 3~ 50 & 60Hz
IP22/55 – Ins.Class.B/F

LANTERNA
MOTORE IN GHISA
CAST IRON
CONNECTION
LANTERN

DISCO INTERNO BRONZO
BRONZE INTERNAL ELEMENT
Marine Bronze as Standard
Custom construction see sec.18

Materiali e caratteristiche indicative da confermare in fase di ordine / Materials and characteristics indicative to be confirmed with the order.



Sentina
Bilge



Incendio
Fire-Fighting



Gasolio
Diesel oil



Alimentazione
impianti
Water supply



Esaurimento
casse
Emptying



Lavaggio
ponte-catena
Deck-chain washing



Acqua
di mare
Sea water



Acque grigie
Grey water



ACM AC



ACM DC

Descrizione

Le pompe singolo e multistadio serie ACM sono autoadescanti ad anello liquido con girante stellare.

Il disegno costruttivo di questa serie garantisce un'eccezionale capacità di adescamento anche con liquidi contenenti aria. L'alta qualità di componenti e materiali (Bronzo, Acciaio Inox.) unitamente alle altre caratteristiche la rendono particolarmente adatta all'utilizzo su Yacht—Megayacht e barche da lavoro.

Description

The pumps single and multi-stage ACM series are self-priming liquid ring pump with star impeller.

The design of this series guarantees an outstanding priming capacity even with liquids containing air. The high quality of materials (Bronze, Stainless Steel.) together with the other features make it particularly suitable for use on Yachts—Megayachts and work boats.



Main features

- Side channel and liquid ring construction
- Outstanding self-priming up to 9 meter vertical
- Shaft pump independently supported
- High quality double mechanical seal

ACM

SELF PRIMING PUMPS



PRESTAZIONI / PERFORMANCES

50Hz – 1450 RPM – AC

		PORTATA / DELIVERY (lt/min)																									
		50	60	70	80	90	100	110	120	130	140	150	180	210													
		PORTATA / DELIVERY (m³/h)																									
		3,0	3,6	4,2	4,8	5,4	6,0	6,6	7,2	7,8	8,4	9,0	10,8	12,6													
		PREVALENZA TOTALE / TOTAL HEAD (mH ₂ O)																									
Versione Version	Potenza kW Power kW	H		H		H		H		H		H		H		H		H		H		H		H			
		kW	H	kW	H	kW	H	kW	H	kW	H	kW	H	kW	H	kW	H	kW	H	kW	H	kW	H	kW	H		
ACM 311BT	1,1			27	1	24	0,9	20	0,9	17	0,8	14	0,8	11	0,7	8	0,7	5	0,6								
	1,5	33	1,4	30	1,3	27	1,3	23	1,2	19	1,2	16	1,1	12	1,1	9	1	6	1	3	0,9						
ACM 312BT	2,2	55	2,1	49	2	44	1,9	39	1,8	33	1,7	27	1,6	22	1,6	16	1,5	11	1,5	5	1,5						
ACM 313BT	3			78	2,9	69	2,8	60	2,7	51	2,6	42	2,5	33	2,5	24	2,4	15	2,4								
ACM 401BT	2,2											38	2,1	36	2	33	1,9	30	1,8	27	1,7	24	1,7	15	1,6	7	1,6
	3,0	51	2,9	48	2,8	46	2,7	43	2,5	41	2,3	38	2,1	36	2	33	1,9	30	1,8	27	1,7	24	1,7	15	1,6	7	1,6
ACM 402BT	4,0											70	3,9	65	3,8	60	3,7	55	3,6	50	3,5	45	3,5	30	3,4	15	3,4
ACM 403BT	5,5																			74	5,3	67	5,2	44	4,6	21	4,4
	7,5											106	6,5	98	6,2	91	6	83	5,8	74	5,6	67	5,4	44	4,9	21	4,6

Legenda: (kW) Potenza assorbita – Prestazioni secondo EN ISO 9906 / Legend: (kW) Absorbed power – Performance in accordance with EN ISO 9906

CURVA CARATTERISTICA / PERFORMANCE CURVE

50Hz – 1450 RPM – AC

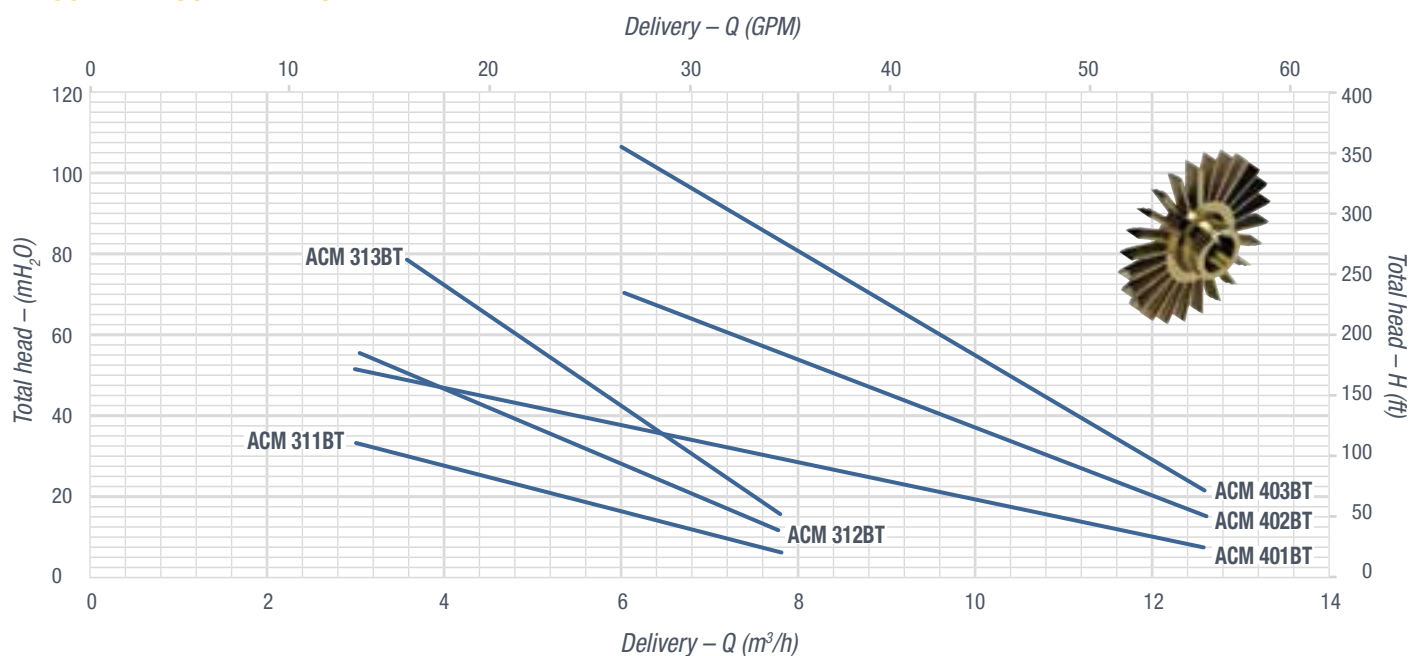

(kW) Potenza assorbita - Tolleranze secondo EN ISO 9906. Caratteristiche tecniche e limitazioni vedi appendice tecnica sezione 18
(kW) Absorbed power - Tolerances in accordance with EN ISO 9906 / Technical features and limitations see technical appendix section 18

DIMENSIONI / DIMENSIONS

Versione / Version	a	b	c	e	f	h	i	g	l	l'	m	n	o	p	DNa	DNm	PN	kg
ACM 311 BT	70	144	35	80	660	247	100	18	170	210	204	135	170	140	32	32	16	55
ACM 312 BT	70	184	35	80	780	247	100	18	170	260	244	135	170	140	32	32	16	67
ACM 313 BT	70	224	35	100	830	247	100	18	170	260	284	135	170	140	32	32	16	80
ACM 401 BT	97	152	55	80	770	270	110	18	198	260	230	155	220	150	40	40	16	75
ACM 402 BT	97	207	55	80	860	270	110	18	198	285	285	155	220	150	40	40	16	85
ACM 403 BT	97	262	55	100	1100	270	110	18	198	310	340	155	220	150	40	40	16	122

Le dimensioni sono indicative. Misure in mm. PN in bar. Caratteristiche tecniche e limitazioni vedi appendice tecnica sezione 8
Dimensions are approximated. Dimensions in mm. PN in bar. Technical features and limitations see technical appendix section 8

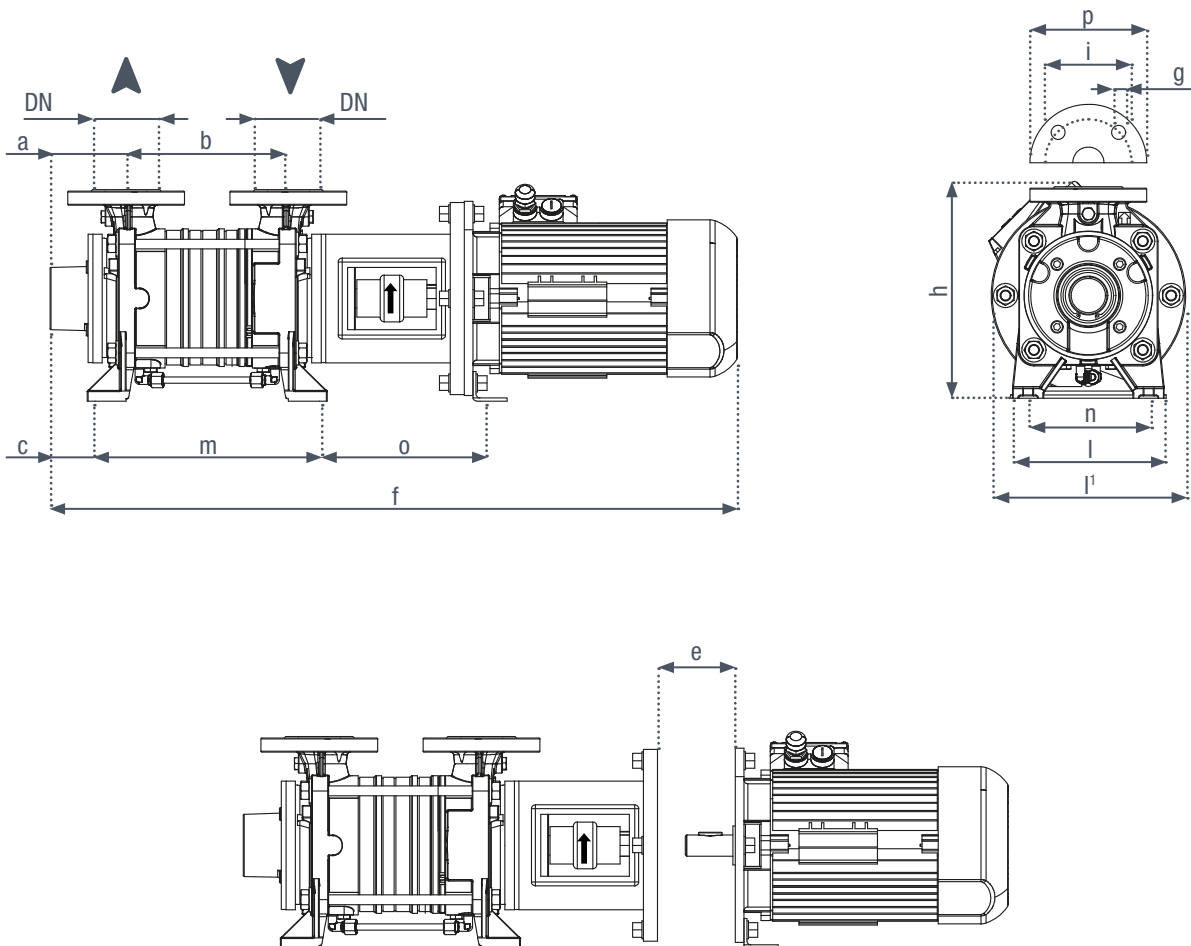

 Vedi sezione 17 "Accessori Compatibili" / See 17 "Compatible Accessories" section

ACM

SELF PRIMING PUMPS



PRESTAZIONI / PERFORMANCES

50Hz – 1450 RPM – AC

		PORTATA / DELIVERY (lt/min)																												
		100	140	180	210	250	300	350	400	450	500	550	600	650	700															
		PORTATA / DELIVERY (m³/h)																												
		6,0	8,4	10,8	12,6	15,0	18,0	21,0	24,0	27,0	30,0	33,0	36,0	39,0	42,0															
		PREVALENZA TOTALE / TOTAL HEAD (mH ₂ O)																												
Versione Version	Potenza kW Power kW	H		H		H		H		H		H		H		H		H		H		H		H		H		H		
		kW	kW	kW	kW	kW	kW	kW	kW	kW	kW	kW	kW	kW	kW	kW	kW	kW	kW	kW	kW	kW	kW	kW	kW	kW	kW	kW	kW	
ACM 501BT	4			36	4	32	3,5	27	3	20	2,8	13	2,6	6	2,4															
	5,5	42	5,4	39	4,5	36	4	32	3,5	27	3	20	2,8	13	2,6	6	2,4													
ACM 502BT	7,5							53	7,4	40	7	26	6,8	14	6,6															
	9,2			83	9	74	8,5	66	7,9	55	7,5	42	7,2	28	7	15	6,8													
ACM 503BT	15					108	14	96	12	80	11	60	10	40	9	20	8													
ACM 651BT	7,5											40	7	35	6,5	30	6	26	5,8	21	5,6	16	5,4	11	5,2	6	5			
	11,0																	51	10	41	9,5	32	9	22	8,5	12	8,2	5	8	
ACM 652BT	15,0											80	14	70	13	60	12	51	10	41	9,5	32	9	22	8,5	12	8,2	5	8	
	22,0											120	21	105	20	91	19	76	18	62	14	47	15	32	14	18	13	10	13	

Legenda: (kW) Potenza assorbita – Prestazioni secondo EN ISO 9906 / Legend: (kW) Absorbed power – Performance in accordance with EN ISO 9906

CURVA CARATTERISTICA / PERFORMANCE CURVE

50Hz – 1450 RPM – AC

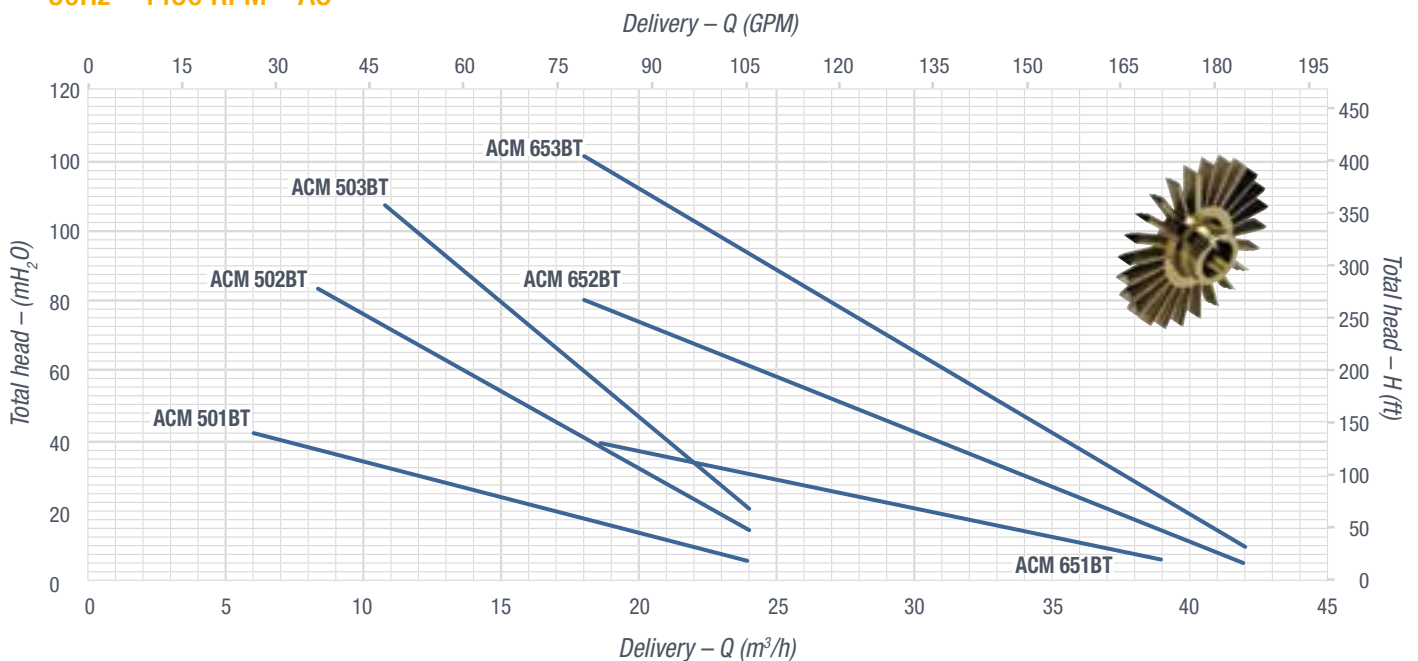

(kW) Potenza assorbita - Tolleranze secondo EN ISO 9906. Caratteristiche tecniche e limitazioni vedi appendice tecnica sezione 18
(kW) Absorbed power - Tolerances in accordance with EN ISO 9906 / Technical features and limitations see technical appendix section 18

DIMENSIONI / DIMENSIONS

Versione / Version	a	b	c	e	f	h	i	g	l	l'	m	n	o	p	DNa	DNm	PN	kg
ACM 501 BT	100	170	60	80	820	325	125	18	215	285	250	170	250	165	50	50	16	91
ACM 502 BT	100	245	60	100	1100	325	125	18	215	320	326	170	250	165	50	50	16	161
ACM 503 BT	100	322	60	150	1300	325	125	18	215	370	402	170	250	165	50	50	16	160
ACM 651 BT	117	190	82	100	980	360	145	18	245	320	270	195	270	185	65	65	16	132
ACM 652 BT	117	280	82	100	1300	360	145	18	245	360	360	195	210	185	65	65	16	210
ACM 653 BT	117	370	82	150	1450	360	145	18	245	360	450	195	210	185	65	65	16	260

Le dimensioni sono indicative. Misure in mm. PN in bar. Caratteristiche tecniche e limitazioni vedi appendice tecnica sezione 8
Dimensions are approximated. Dimensions in mm. PN in bar. Technical features and limitations see technical appendix section 8

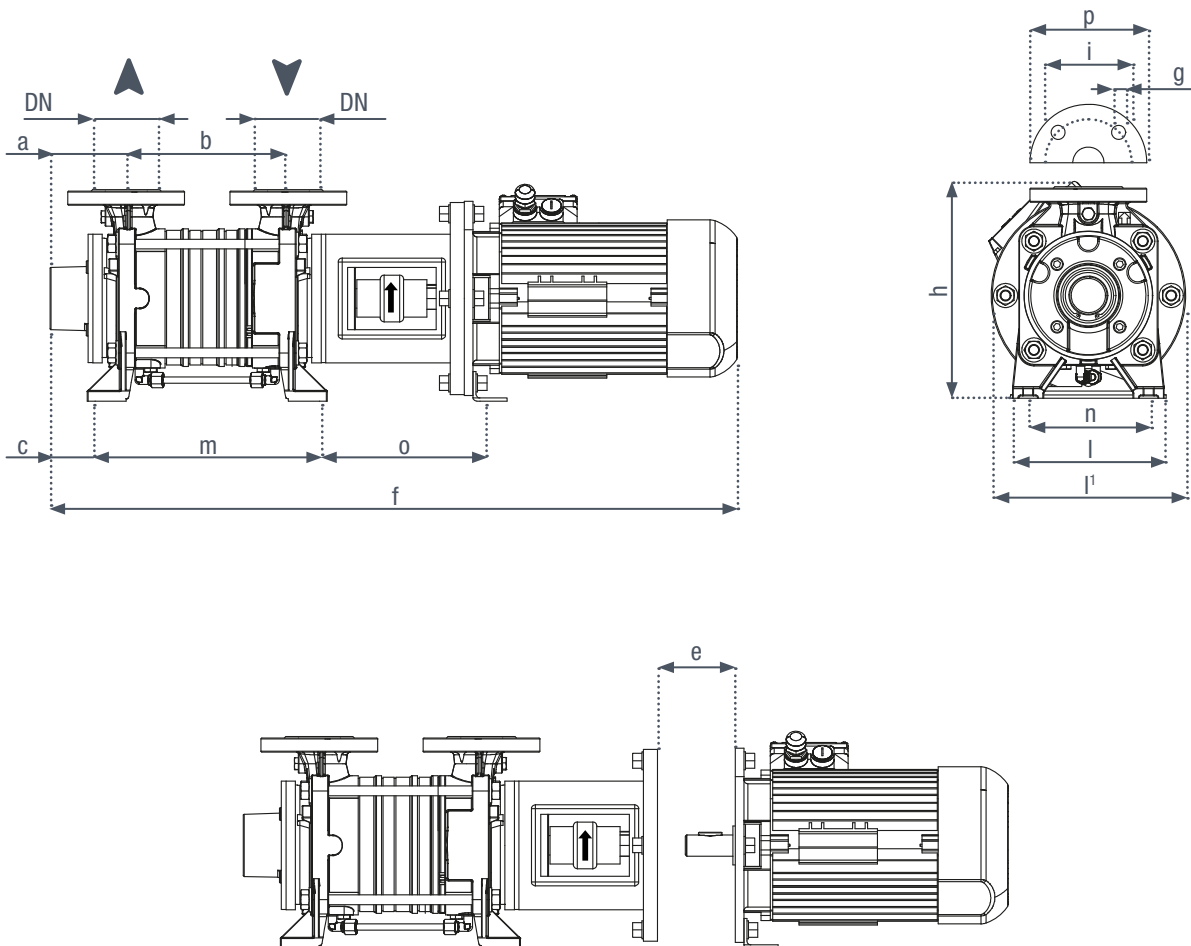

 Vedi sezione 17 "Accessori Compatibili" / See 17 "Compatible Accessories" section

ACM

SELF PRIMING PUMPS



PRESTAZIONI / PERFORMANCES

60Hz – 1750 RPM – AC

Versione Version	Potenza kW Power kW	PORTATA / DELIVERY (lt/min)																							
		50	70	80	90	100	110	120	130	140	150	180	210	250											
		PORTATA / DELIVERY (m³/h)																							
		3,0	4,2	4,8	5,4	6,0	6,6	7,2	7,8	8,4	9,0	10,8	12,6	15,0											
		PREVALENZA TOTALE / TOTAL HEAD (mH ₂ O)																							
		H	kW	H	kW	H	kW	H	kW	H	kW	H	kW	H	kW	H	kW	H	kW	H	kW	H	kW	H	kW
ACM 311BT	1,5					32	1,5	28	1,4	24	1,4	21	1,3	17	1,3	13	1,2	9	1,2						
	2,2	46	1,8	40	1,7	36	1,6	32	1,5	28	1,4	24	1,4	21	1,3	17	1,3	13	1,2	9	1,2				
ACM 312BT	3					57	3	51	2,9	44	2,8	38	2,7	31	2,7	24	2,6	17	2,6						
	4			70	3,4	64	3,2	57	3	51	2,9	44	2,8	38	2,7	31	2,7	24	2,6	17	2,6				
ACM 313BT	5,5			110	5,2	100	5	91	4,9	80	4,8	69	4,7	58	4,7	47	4,6	36	4,6	25	4,5				
ACM 401BT	3,0															45	3	42	2,9	32	2,8	22	2,7	9	2,7
	4,0									55	3,7	52	3,4	48	3,2	45	3	42	2,9	32	2,8	22	2,7	9	2,7
ACM 402BT	5,5																80	5,5	61	5,3	42	5,1	17	5	
	7,5											100	7,5	93	6,5	87	6	80	5,5	61	5,3	42	5,1	17	5
ACM 403BT	9,2																	93	8,5	64	8,2	25	8		
	11,0											150	11	142	10	133	9,5	123	9	93	8,5	64	8,2	25	8

Legenda: (kW) Potenza assorbita – Prestazioni secondo EN ISO 9906 / Legend: (kW) Absorbed power – Performance in accordance with EN ISO 9906

CURVA CARATTERISTICA / PERFORMANCE CURVE

60Hz – 1750 RPM – AC

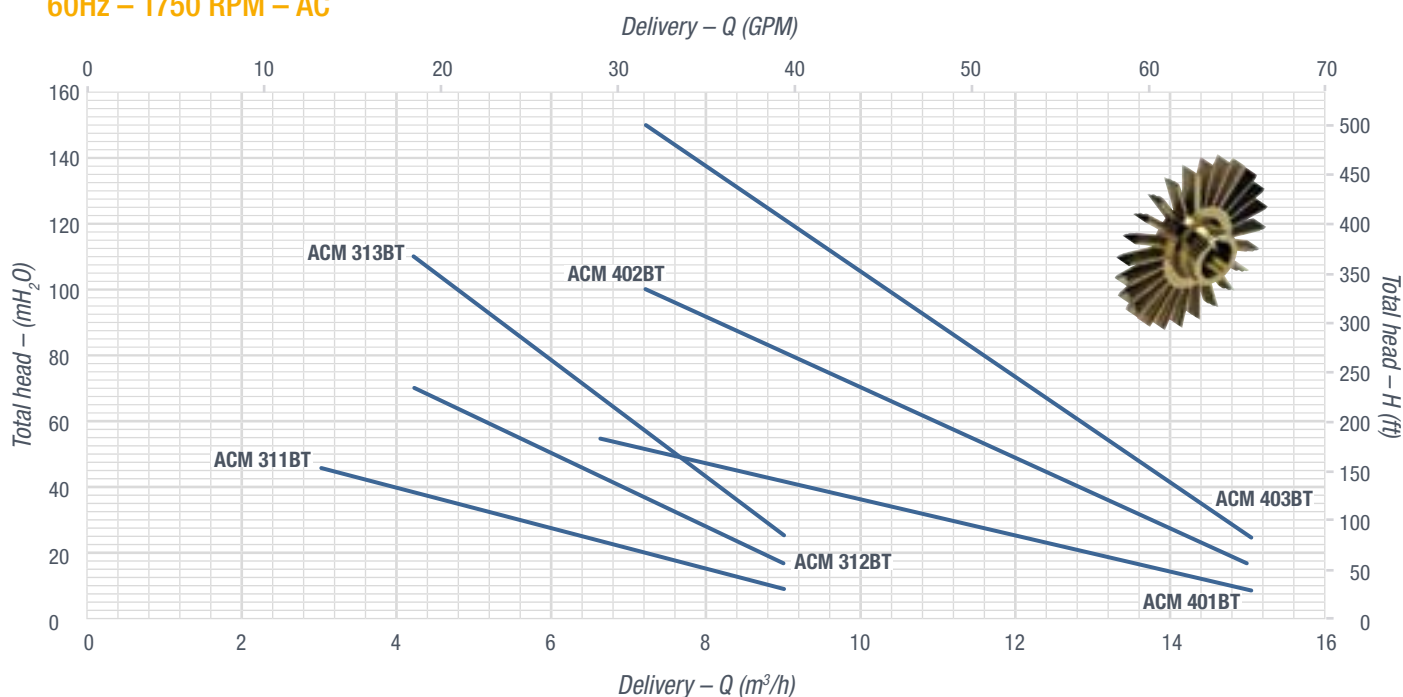

(kW) Potenza assorbita - Tolleranze secondo EN ISO 9906. Caratteristiche tecniche e limitazioni vedi appendice tecnica sezione 18
(kW) Absorbed power - Tolerances in accordance with EN ISO 9906 / Technical features and limitations see technical appendix section 18



DIMENSIONI / DIMENSIONS

Versione / Version	a	b	c	e	f	h	i	g	l	l'	m	n	o	p	DNa	DNm	PN	kg
ACM 311 BT	70	144	35	80	710	247	100	18	170	260	204	135	170	140	32	32	16	65
ACM 312 BT	70	184	35	80	830	247	100	18	170	260	244	135	170	140	32	32	16	80
ACM 313 BT	70	224	35	100	880	247	100	18	170	310	284	135	170	140	32	32	16	103
ACM 401 BT	97	152	55	80	810	270	110	18	198	260	230	155	220	150	40	40	16	80
ACM 402 BT	97	207	55	80	920	270	110	18	198	310	285	155	220	150	40	40	16	122
ACM 403 BT	97	262	55	100	1100	270	110	18	198	310	340	155	220	150	40	40	16	183

Le dimensioni sono indicative. Misure in mm. PN in bar. Caratteristiche tecniche e limitazioni vedi appendice tecnica sezione 8
Dimensions are approximated. Dimensions in mm. PN in bar. Technical features and limitations see technical appendix section 8

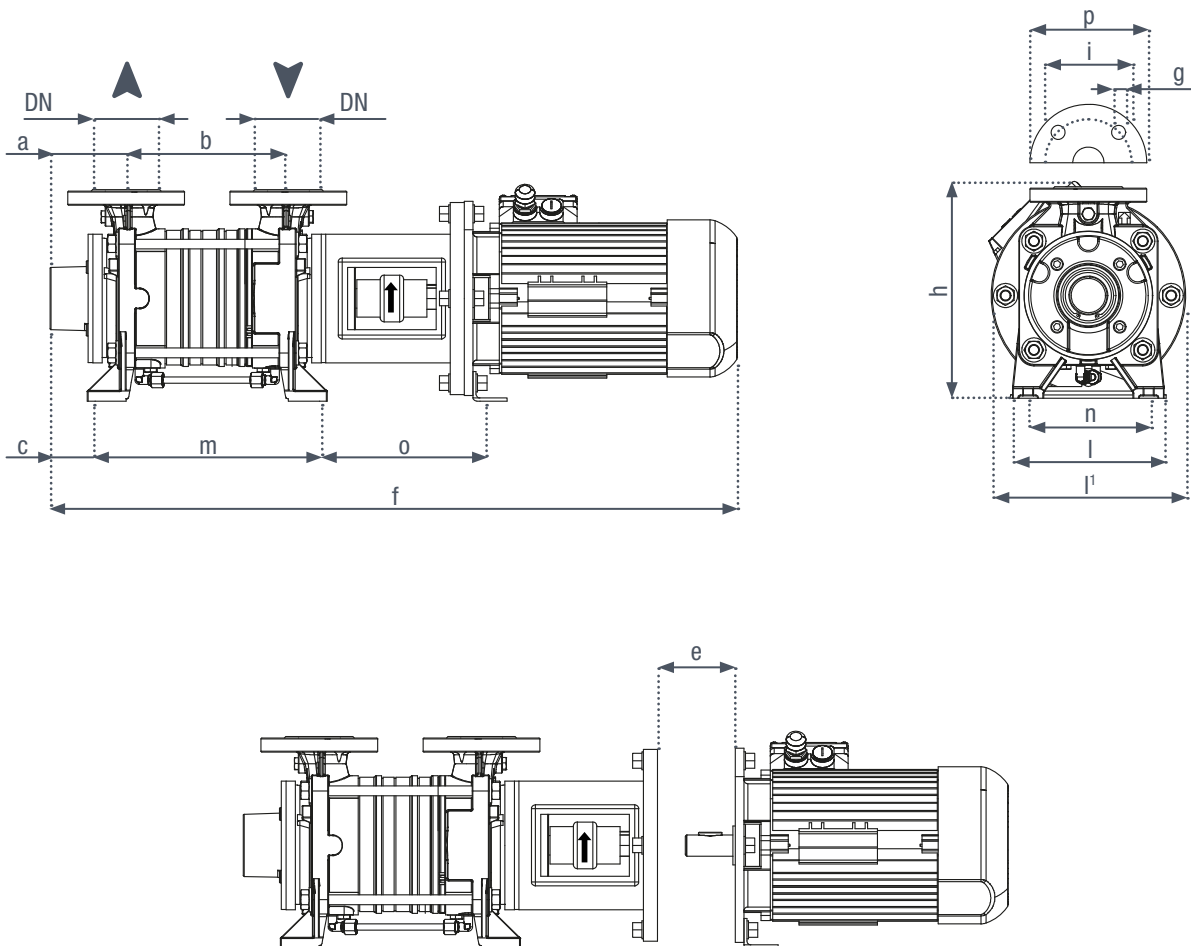

 Vedi sezione 17 "Accessori Compatibili" / See 17 "Compatible Accessories" section

ACM

SELF PRIMING PUMPS



PRESTAZIONI / PERFORMANCES

60Hz – 1750 RPM – AC

Versione Version	Potenza kW Power kW	PORTATA / DELIVERY (lt/min)																					
		250	300	350	400	450	500	550	600	650	700	750	780										
		PORTATA / DELIVERY (m³/h)																					
		15,0	18,0	21,0	24,0	27,0	30,0	33,0	36,0	39,0	42,0	45,0	47,0										
PREVALENZA TOTALE / TOTAL HEAD (mH ₂ O)																							
		H	kW	H	kW	H	kW	H	kW	H	kW	H	kW	H	kW	H	kW	H	kW	H	kW	H	kW
ACM 501BT	5,5			42	5,4	33	5	23	4,6	13	4,2	3	3,8										
	7,5	51	7,4	42	5,4	33	5	23	4,6	13	4,2	3	3,8										
ACM 502BT	11					61	10,5	44	9	27	7,5	10	7										
	15	96	14,8	78	12,5	61	10,5	44	9	27	7,5	10	7										
ACM 503BT	18,5			119	18	93	14	67	3	41	12	15	11										
	9,2													29	9	23	8	17	7,5	11	7	6	7
ACM 651BT	11,0													36	10,5	29	9	23	8	17	7,5	11	7
	15,0					61	14,5	55	13,5	48	12,5	42	11,5	36	10,5	29	9	23	8	17	7,5	11	7
	18,5															56	18	44	17	32	16	20	15
ACM 652BT	22,0																						
	30,0													80	21	68	19,5	56	18	44	17	32	16
ACM 653BT	30,0													119	29	102	27	85	25	68	23	51	21

Legenda: (kW) Potenza assorbita – Prestazioni secondo EN ISO 9906 / Legend: (kW) Absorbed power – Performance in accordance with EN ISO 9906

CURVA CARATTERISTICA / PERFORMANCE CURVE

60Hz – 1750 RPM – AC

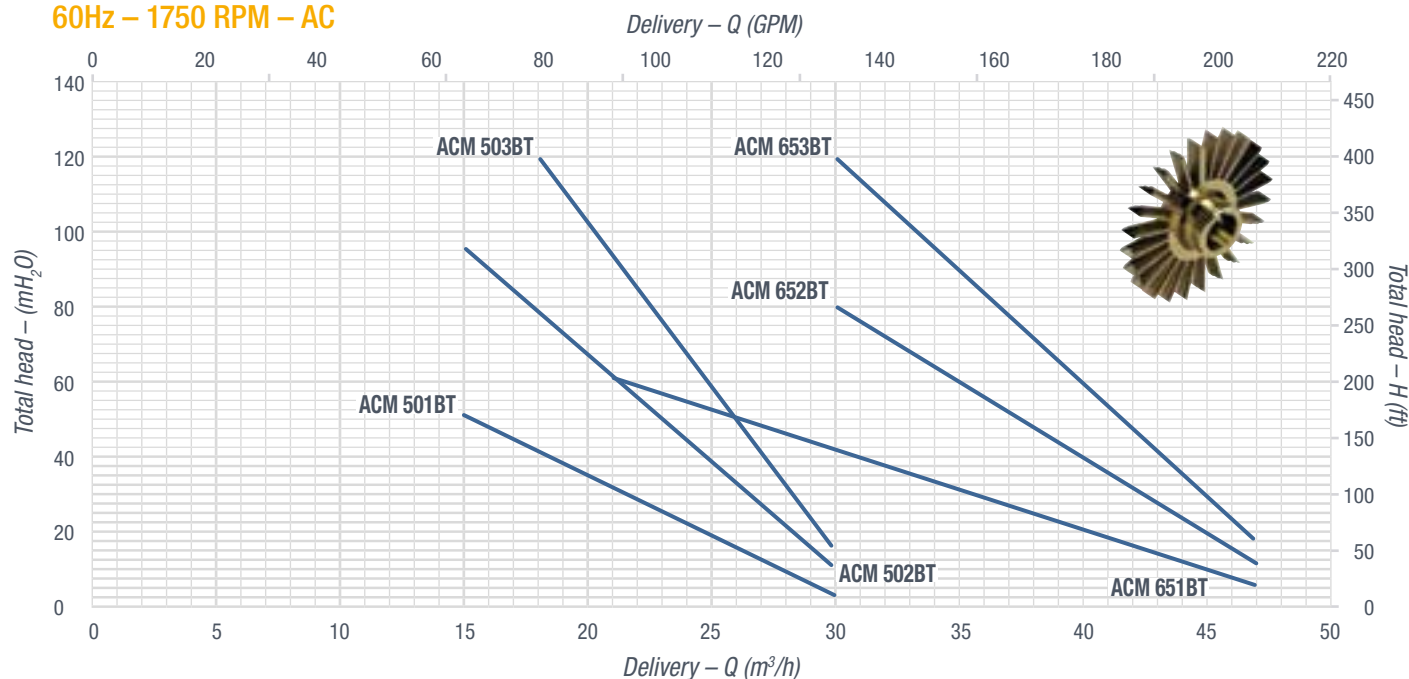

(kW) Potenza assorbita - Tolleranze secondo EN ISO 9906. Caratteristiche tecniche e limitazioni vedi appendice tecnica sezione 18
(kW) Absorbed power - Tolerances in accordance with EN ISO 9906 / Technical features and limitations see technical appendix section 18

DIMENSIONI / DIMENSIONS

Versione / Version	a	b	c	e	f	h	i	g	l	l'	m	n	o	p	DNa	DNm	PN	kg
ACM 501 BT	100	170	60	100	880	325	125	18	215	310	250	170	250	165	50	50	16	115
ACM 502 BT	100	245	60	150	1210	325	125	18	215	370	326	170	250	165	50	50	16	205
ACM 503 BT	100	322	60	150	1340	325	125	18	215	390	402	170	250	165	50	50	16	185
ACM 651 BT	117	190	82	150	1060	360	145	18	245	370	270	195	270	185	65	65	16	185
ACM 652 BT	117	280	82	200	1430	360	145	18	245	390	360	195	210	185	65	65	16	265
ACM 653 BT	117	370	82	200	1550	360	145	18	245	390	450	195	210	185	65	65	16	305

Le dimensioni sono indicative. Misure in mm. PN in bar. Caratteristiche tecniche e limitazioni vedi appendice tecnica sezione 8
Dimensions are approximated. Dimensions in mm. PN in bar. Technical features and limitations see technical appendix section 8

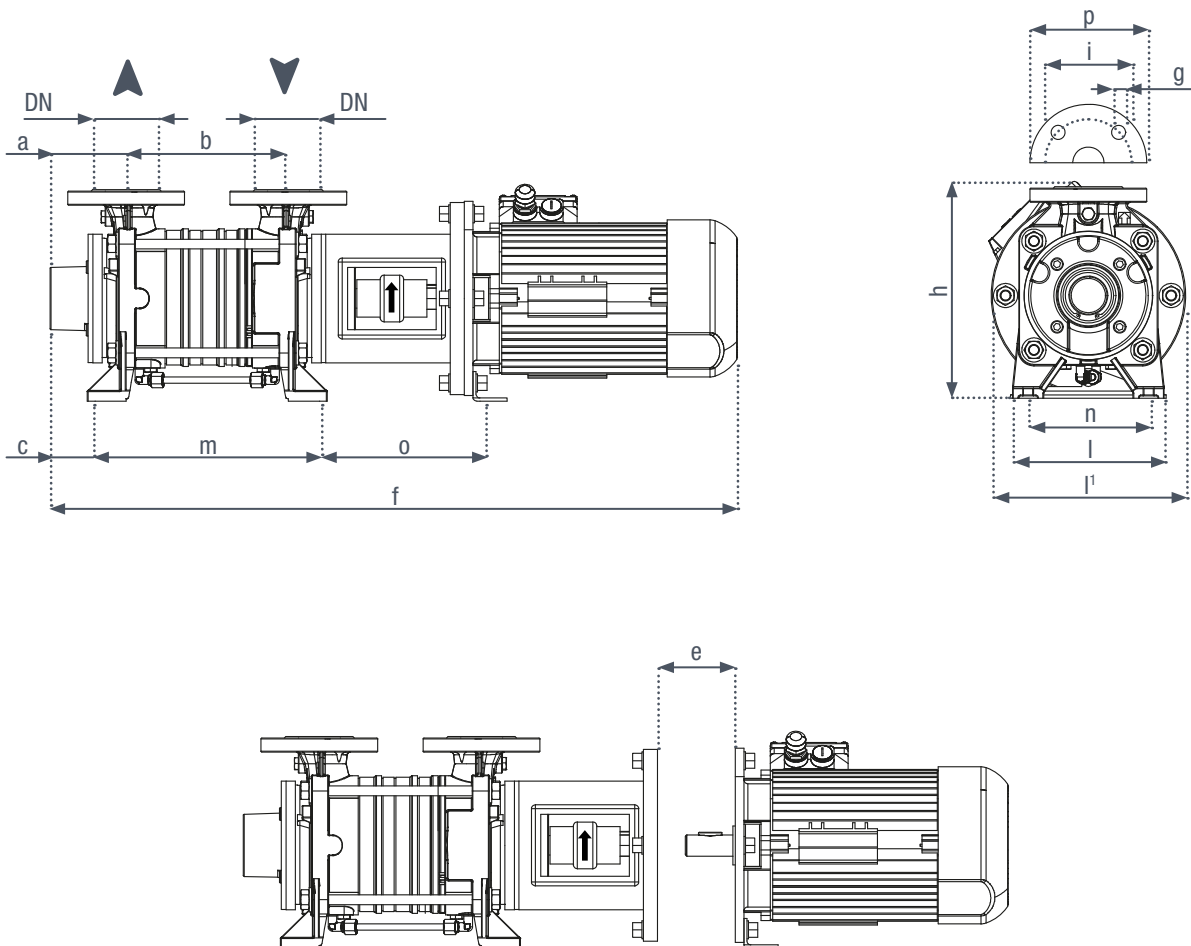

 Vedi sezione 17 "Accessori Compatibili" / See 17 "Compatible Accessories" section

ACM

SELF PRIMING PUMPS



PRESTAZIONI / PERFORMANCES

1500 RPM – DC

Versione Version	Potenza kW Power kW	PORTATA / DELIVERY (lt/min)																									
		50	60	70	80	90	100	110	120	130	140	150	180	210	230												
		PORTATA / DELIVERY (m ³ /h)																									
		3,0	3,6	4,2	4,8	5,4	6,0	6,6	7,2	7,8	8,4	9,0	10,8	12,6	13,8												
		PREVALENZA TOTALE / TOTAL HEAD (mH ₂ O)																									
		H	A	H	A	H	A	H	A	H	A	H	A	H	A	H	A	H	A	H	A	H	A				
ACM 311BT	1					25	60	22	56	20	47	17	41	14	34	11	28	8	24	6	20						
ACM 312BT	1,5	46	90	41	86	36	81	31	76	27	71	28	64	24	59	20	55	16	51	9	48	8	36				
ACM 401BT	1,5									30	90	27	88	25	84	23	78	21	74	19	69	13	65	8	63	3	59

Legenda / Legend: (A) Corrente Assorbita / (A) Absorbed current at rated voltage

CURVA CARATTERISTICA / PERFORMANCE CURVE

1500 RPM – DC

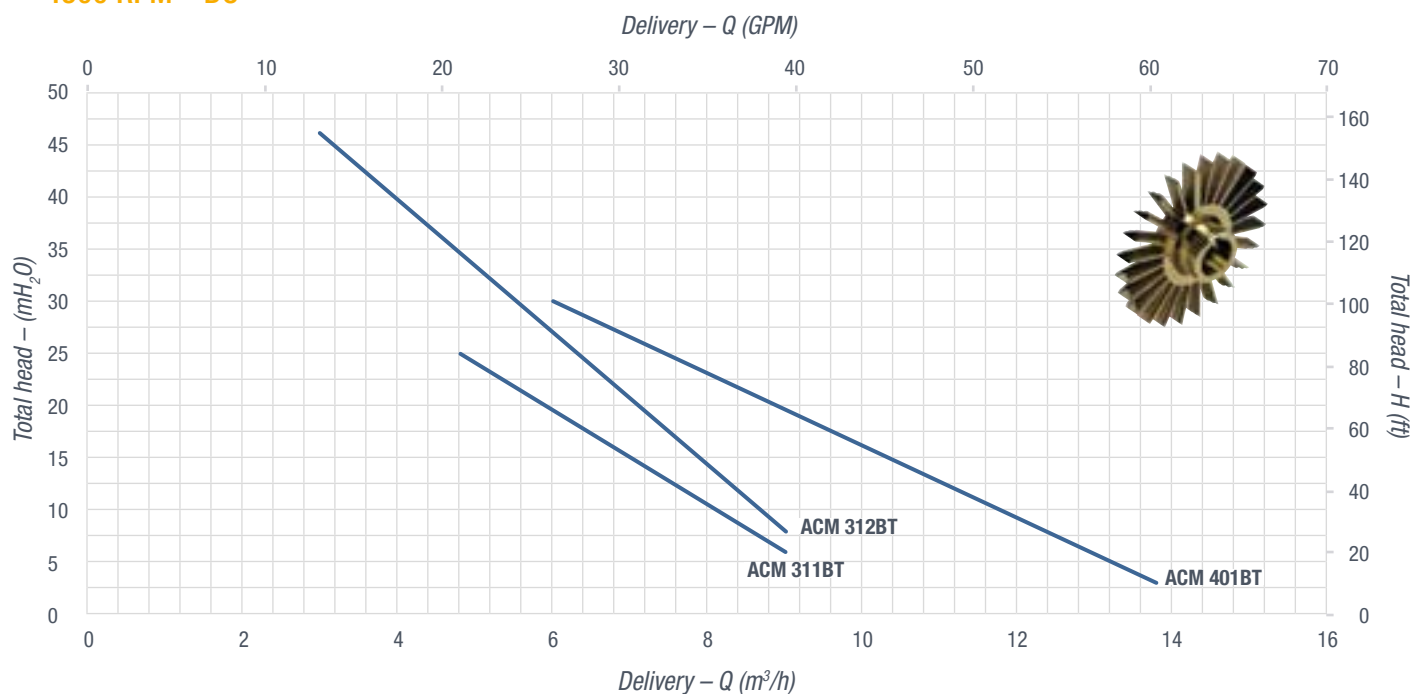

(A) Corrente assorbita - Tolleranze secondo EN ISO 9906. Caratteristiche tecniche e limitazioni vedi appendice tecnica sezione 18

(A) Absorbed current at rated voltage - Tollerances in accordance with EN ISO 9906. Technical features and limitations see technical appendix section 18

DIMENSIONI / DIMENSIONS

Versione / Version	a	b	c	e	f	h	i	g	l	l'	m	n	o	p	DNa	DNm	PN	kg
ACM 311BT	70	144	35	80	700	247	100	18	170	200	204	135	170	140	32	32	16	52
ACM 312BT	70	184	35	80	790	247	100	18	170	250	244	135	105	140	32	32	16	73
ACM 401BT	100	152	55	80	800	272	110	18	195	250	230	155	220	150	40	40	16	79

Le dimensioni sono indicative. Misure in mm. PN in bar. Caratteristiche tecniche e limitazioni vedi appendice tecnica sezione 8
Dimensions are approximated. Dimensions in mm. PN in bar. Technical features and limitations see technical appendix section 8

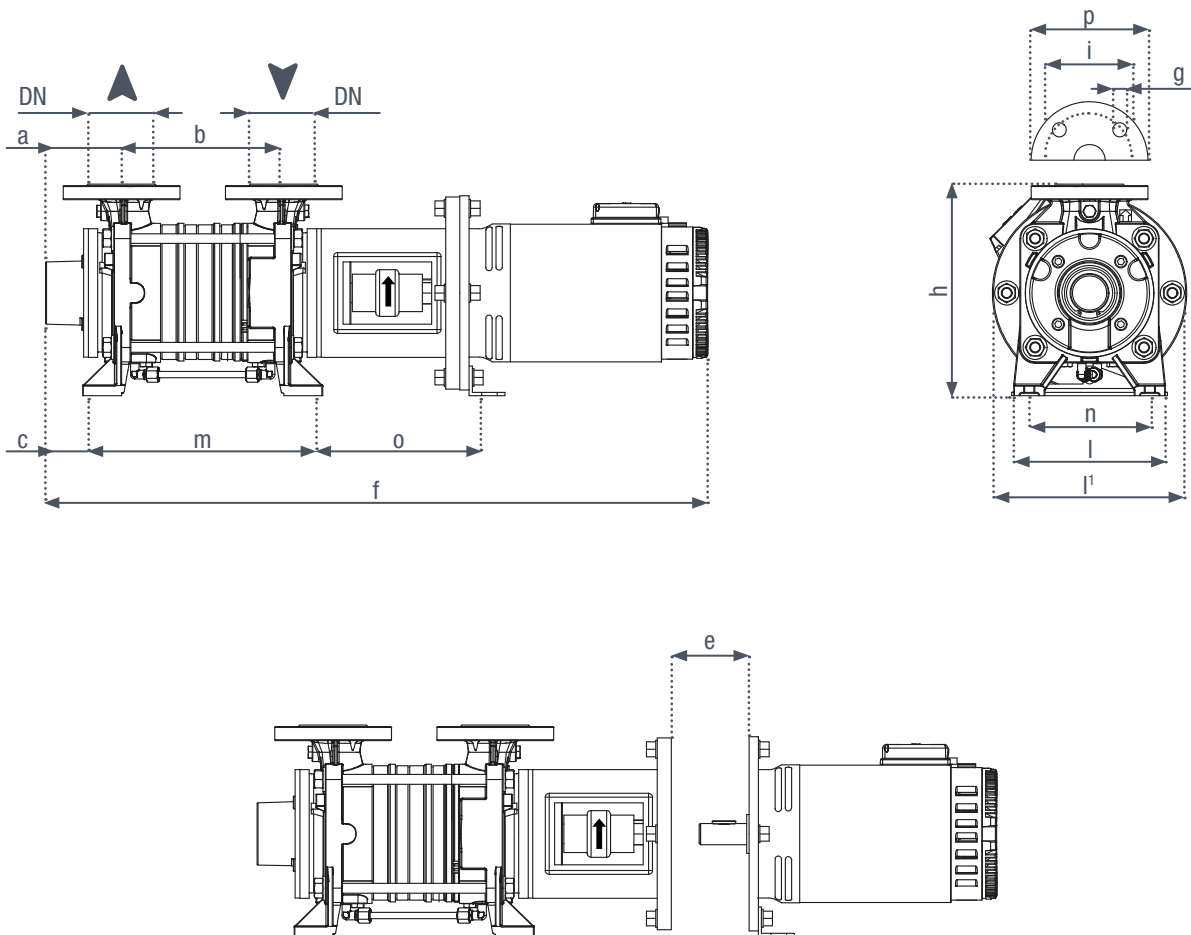

 Vedi sezione 17 "Accessori Compatibili" / See 17 "Compatible Accessories" section